

Aufbauanleitung  
Instructions de montage  
Istruzioni di montaggio  
Instrucciones de montaje  
Instruções de montagem

Art nr:54133003



Ein detailliertes Montagevideo finden Sie unter folgendem Link oder indem Sie den QR-Code scannen:  
Sous le lien suivant ou en scannant le code QR, vous trouverez une vidéo de montage détaillée  
Encontrarás un detallado video del montaje en el siguiente enlace o escaneando el código QR.  
Un video dettagliato del montaggio è disponibile al seguente link o scansionando il codice QR.  
Encontrará um vídeo de montagem detalhado no seguinte link ou ao digitalizar o código QR.  
Podeu trobar un vídeo detallat del muntatge a l'enllaç següent o escanejant el codi QR indicat a continuació:

<https://www.youtube.com/watch?v=NGZnserpHuA>

Lesen Sie zuerst die Anleitung und beginnen Sie dann mit der Montage.

Lisez tout d'abord les instructions de montage avant de commencer le montage.

Cominciate con il montaggio soltanto dopo aver letto le istruzioni.

Por favor lea las instrucciones antes de llevar a cabo el montaje.

Si us plau llegiu les instruccions abans de dur a terme el muntatge.

Leia primeiro as instruções e comece depois com a montagem

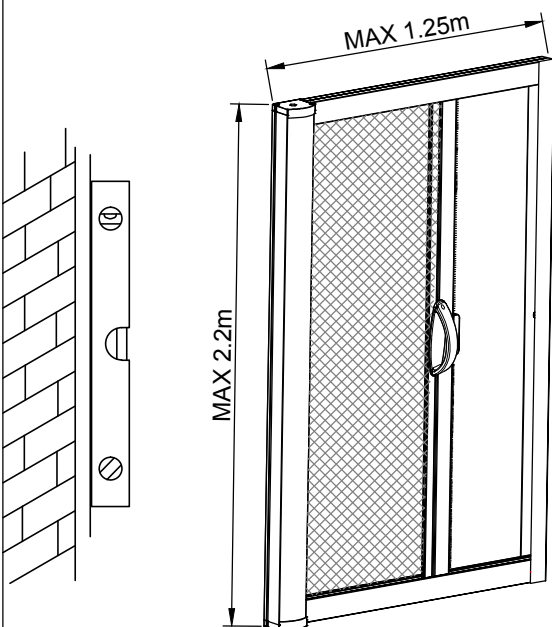

60 min

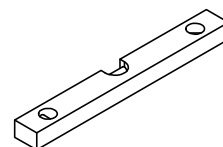
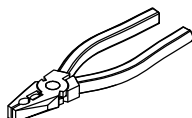
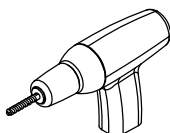
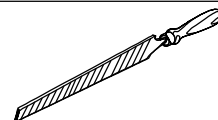
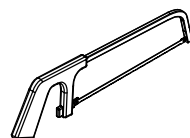
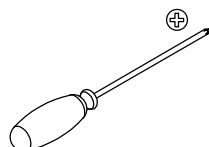
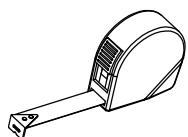
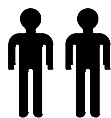

① x1

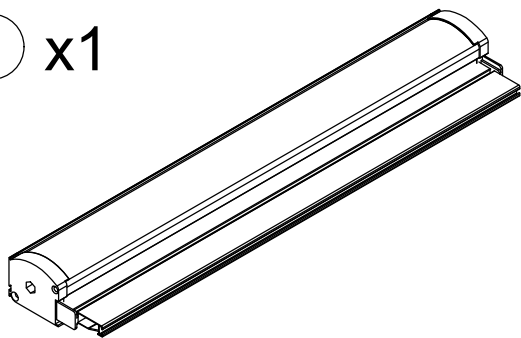

2200x91x45mm

② x2

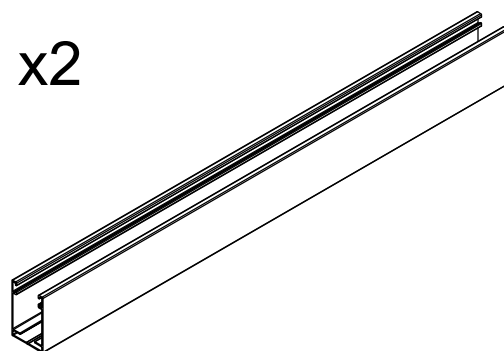

1200x31x20mm

③ x1

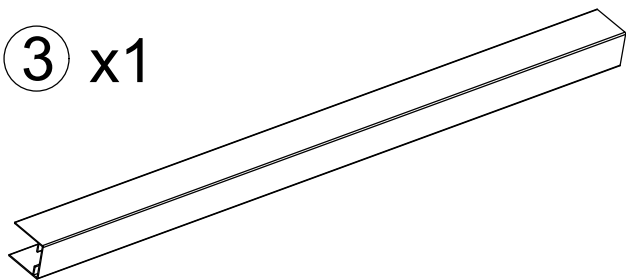

2200x25x23mm

④ x2

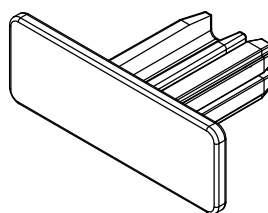

42.5x25.5x15mm

⑤ x1

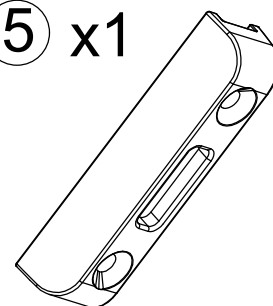

55x14x11.5mm

⑥ x2

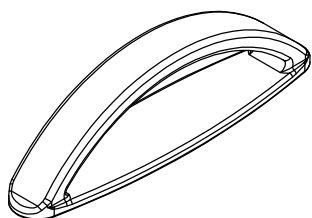

111x33x25mm

⑦ x1

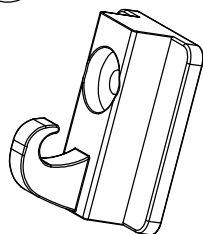

24x19x16.5mm

⑧ x3

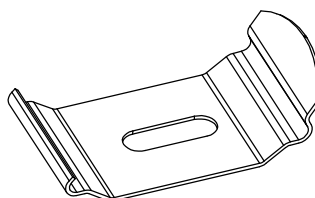

41.5x20x10mm

⑨ x2



M4x8

⑩ x10

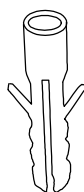

Ø10x31

⑪ x10



M4x25

⑫ x2

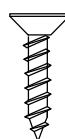

M4x16

⑬ x1



M3x9

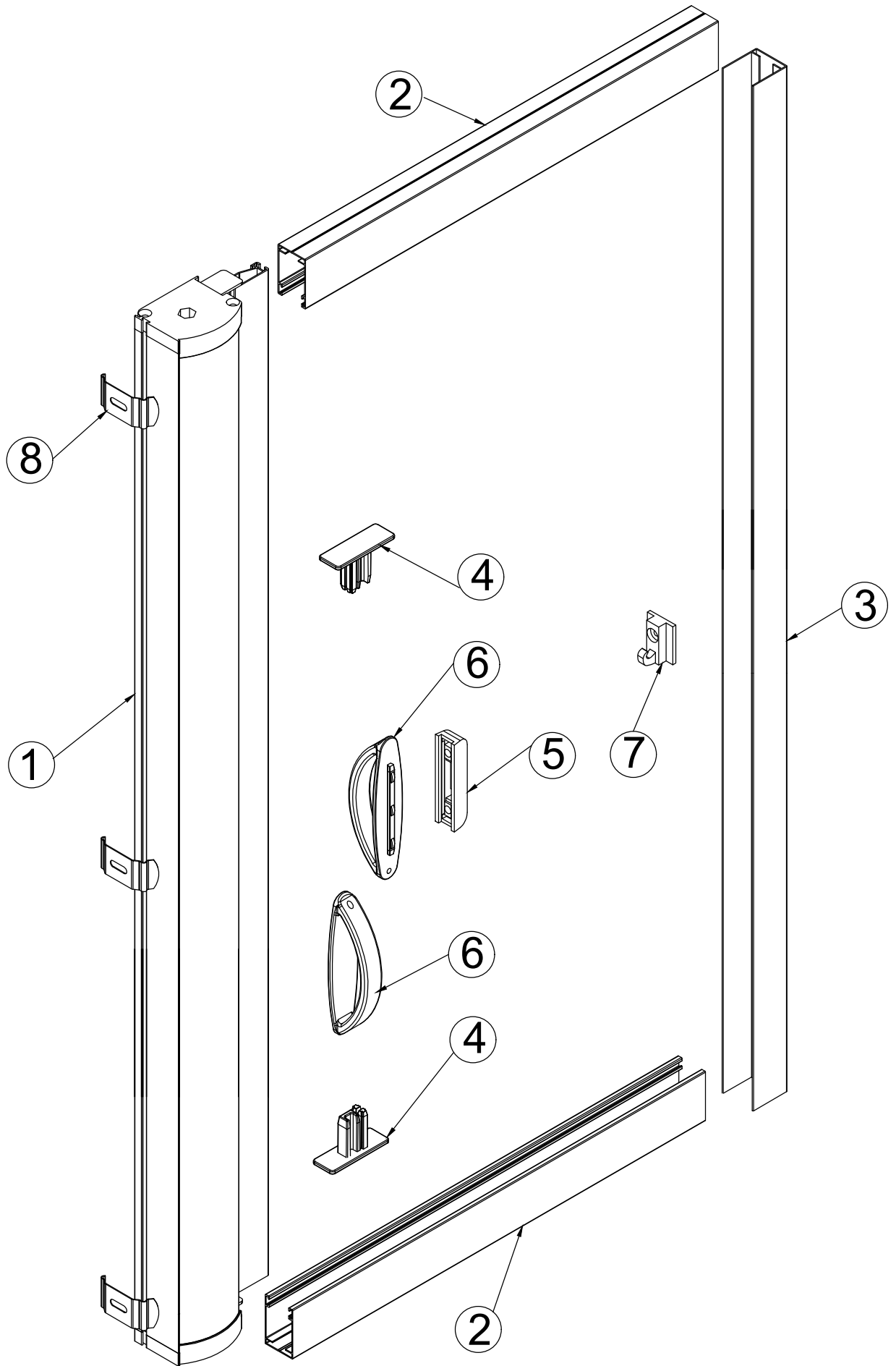

1

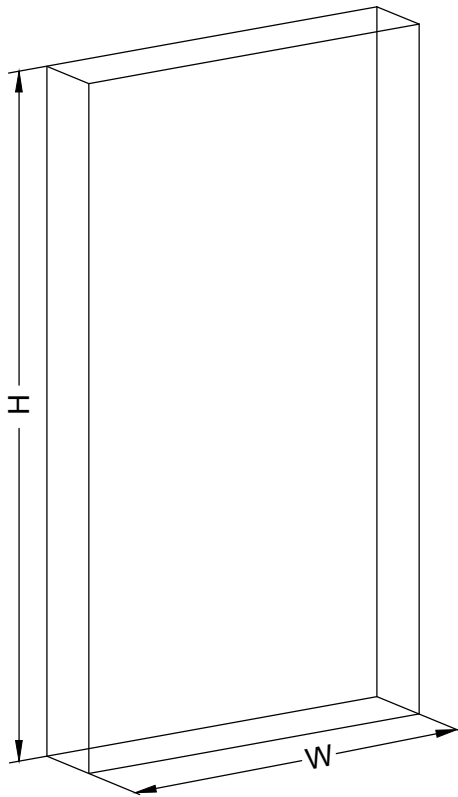
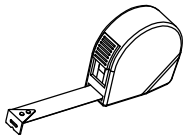

Höhe mindestens 90cm  
Breite mindestens 60cm  
Mindestlaibungstiefe: 6cm  
Für Tür bis max. 125 x 220 cm  
Vermessen Sie die Höhe und Breite der Türlaibung

Hauteur minimum : 90 cm  
Largeur minimum : 60 cm  
Profondeur minimum du cadre de la porte : 6 cm  
Dimensions maximum de la porte (L.) 125 x (H.) 220 cm  
Mesurez la hauteur (H.) et la largeur (L.) du cadre de la porte

Altezza minima: 90 cm  
Larghezza minima: 60 cm  
Profondità minima dello stipite della porta: 6 cm  
Misura max. della porta (Largh.) 125 x (Alt.) 220 cm  
Misurare l'altezza (Alt.) e la larghezza (Largh.) dello stipite della porta

Altura mínima: 90 cm  
Anchura mínima: 60 cm  
Profundidad mínima del marco de la puerta: 6 cm  
Tamaño máximo de la puerta (an.) 125 x (al.): 220 cm  
Mida la altura (al.) y la anchura (an.) del marco de la puerta

Altura mínima: 90 cm  
Amplada mínima: 60 cm  
Profunditat mínima del marc de la porta: 6 cm  
Mida màxima de la porta (Am.) 125 x (Al.) 220 cm  
Mesureu l'alçada (Al.) i l'amplada (Am.) del marc de la porta

Altura mínima: 90 cm  
Largura mínima: 60 cm  
Profundidade mínima do intradorso da porta: 6 cm  
Tamanho máximo da porta (L) 125 x (A) 220 cm  
Medir a altura (A) e a largura (L) do intradorso da porta

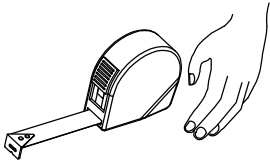

2

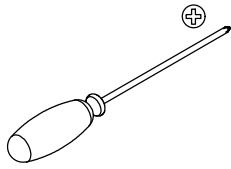

① x1

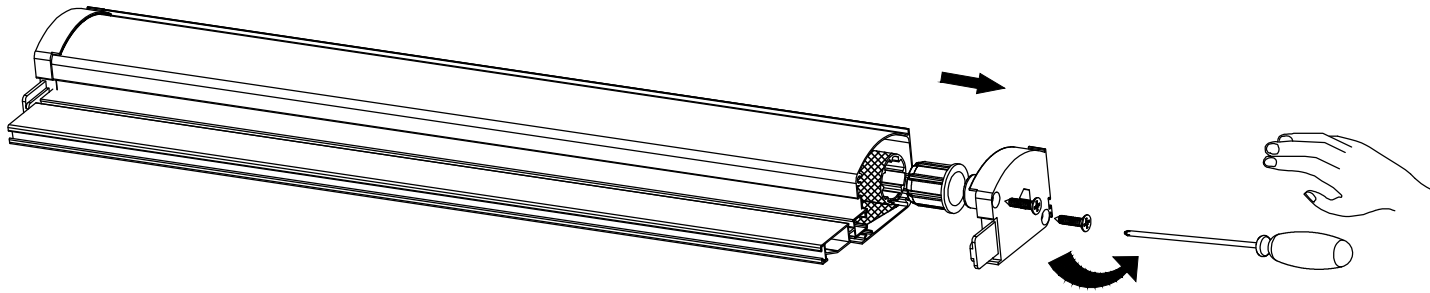
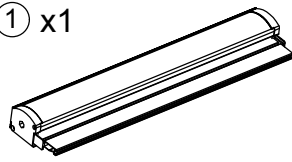

Ziehen Sie das rechte Endstück auf der rechten Seite der Kassette heraus.

Retirez le capuchon droit à la droite de la cassette (partie 1).

Staccare il terminale destro della cassetta (pezzo 1).

Retire el extremo derecho del lado derecho del cajón (parte 1).

Traieu l'extrem dret del cantó dret del calaix (part 1).

Tire a parte final do lado direito da cassetete (parte 1).

# 3

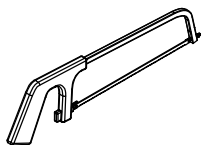

① x1

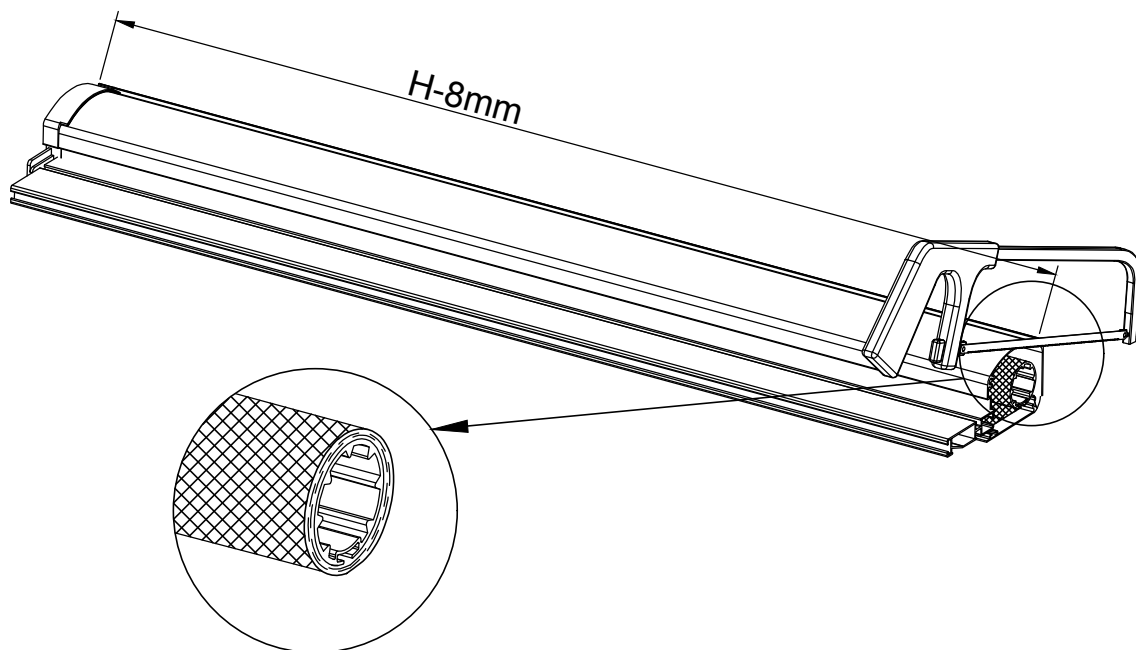
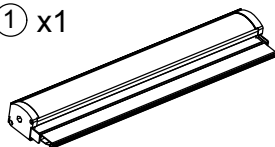

Zum Kürzen der Kassette, nehmen Sie die gemessene Höhe (H) minus 8mm.

Kürzen Sie die Kassette anschließend mit einer Säge.

Stellen Sie vor dem Sägen sicher, dass sich das Insektenschutzrollo vollständig innerhalb der Kassette befindet.

Pour raccourcir le support, prendre la hauteur mesurée (H) moins 8 mm  
Coupez la cassette avec une scie.

Assurez-vous avant de scier que le store de protection anti-insectes se trouve entièrement dans la cassette.

Per accorciare la cassetta, misurare l'altezza (H) e sottrarre 8 mm

Accorciare la cassetta servendosi di un seghetto.

Assicurarsi che la zanzariera sia completamente all'interno della cassetta prima di accorciare.

Para acortar la carcasa, tome la medida de la altura (H) y réstele 8 mm

A continuación, recorte el cajón con una sierra. Asegúrese de que toda la red está dentro del cajón antes de serrar.

Per retallar la carcassa, preneu la mida de l'altura (H) i resteu-hi 8 mm.

A continuació, retalleu el calaix amb una serra. Assegureu-vos que tota la malla està dins del calaix abans de serrar.

Para reduzir o tamanho do suporte, tire 8 mm à altura medida (H).

Depois utilize uma serra para reduzir a cassete.

Certifique-se de que a rede esteja totalmente no interior da cassete antes de serrar.

4

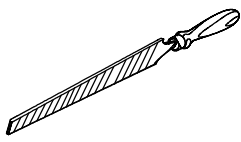

① x1

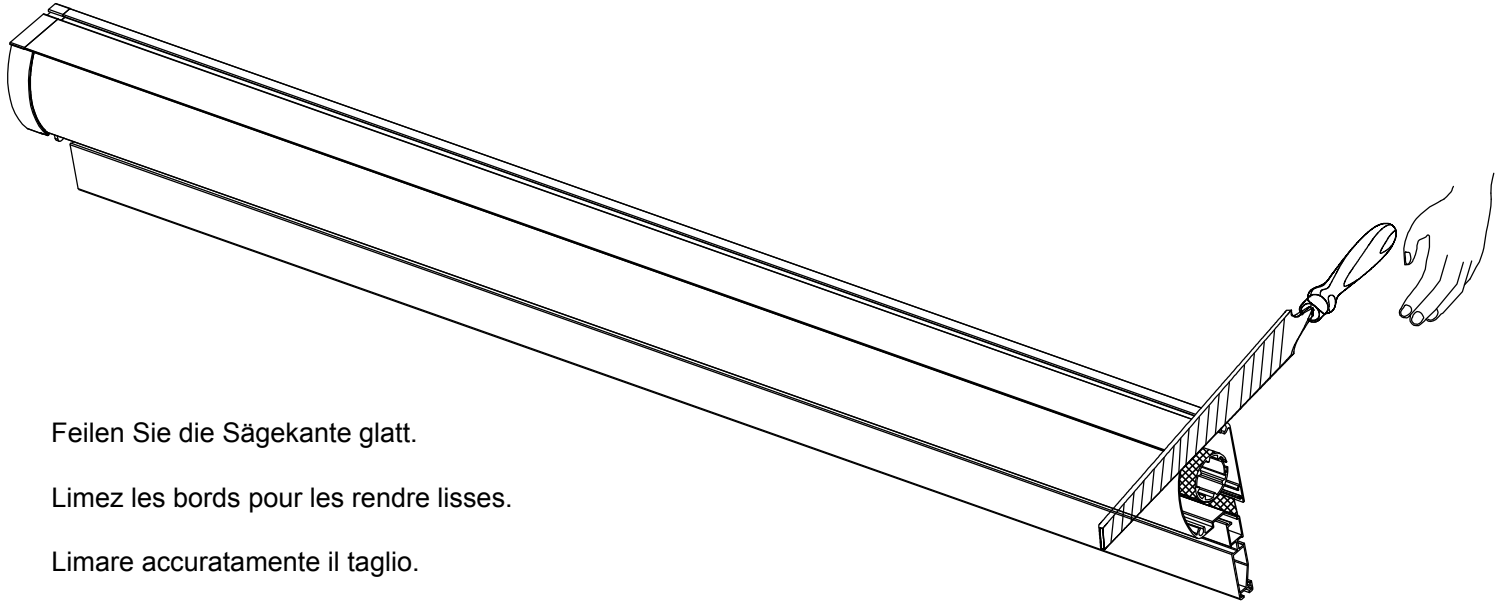
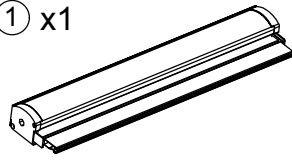

Feilen Sie die Sägekante glatt.



Limez les bords pour les rendre lisses.

Limare accuratamente il taglio.

Lije el corte.

Escateu el tall.

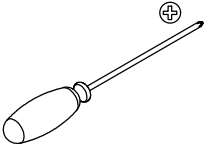
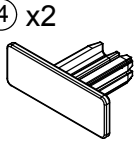
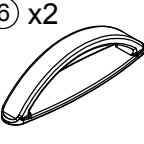
Faça o corte suavemente.

5					
---	---	---	---	---	--

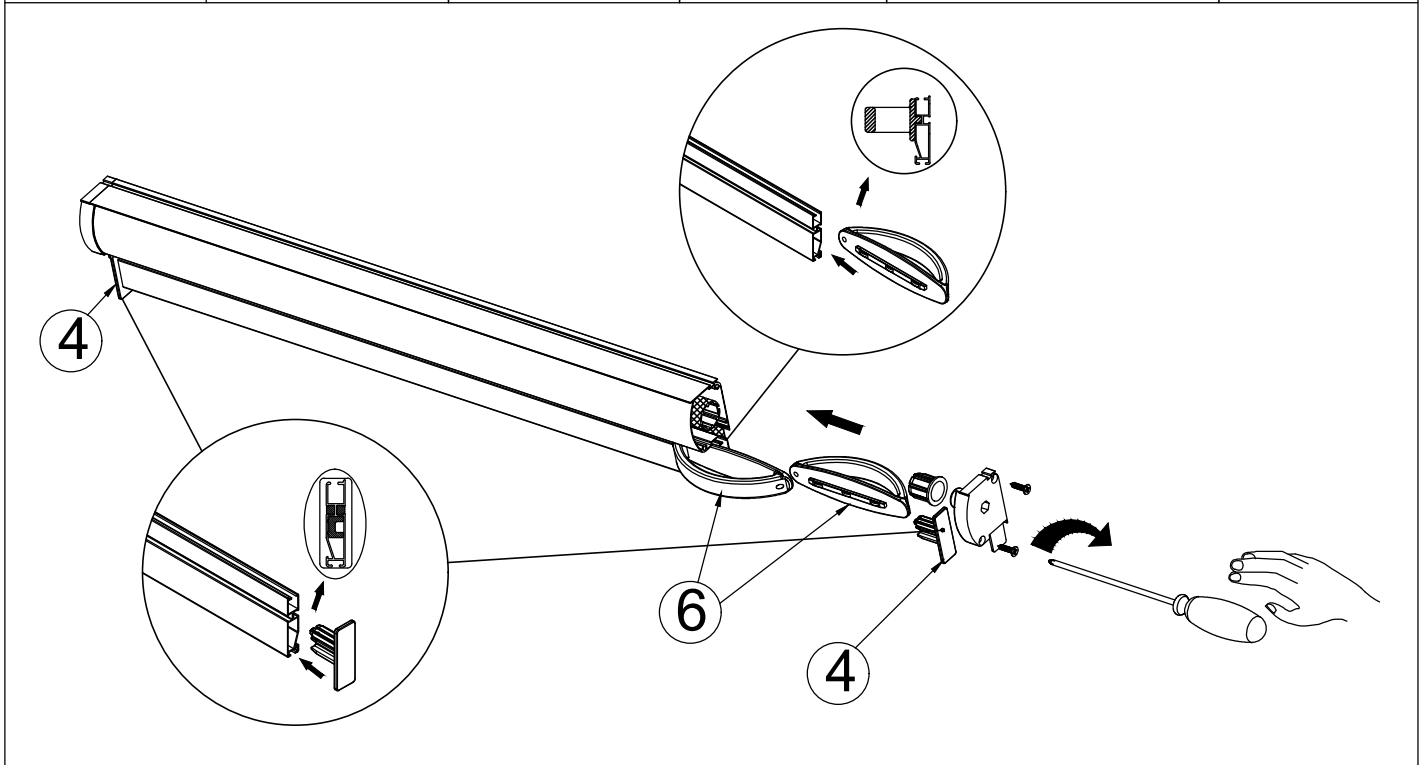

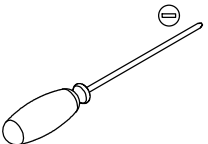
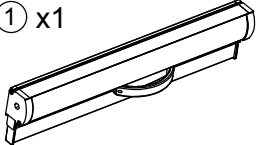
6				
---	---	---	--	--

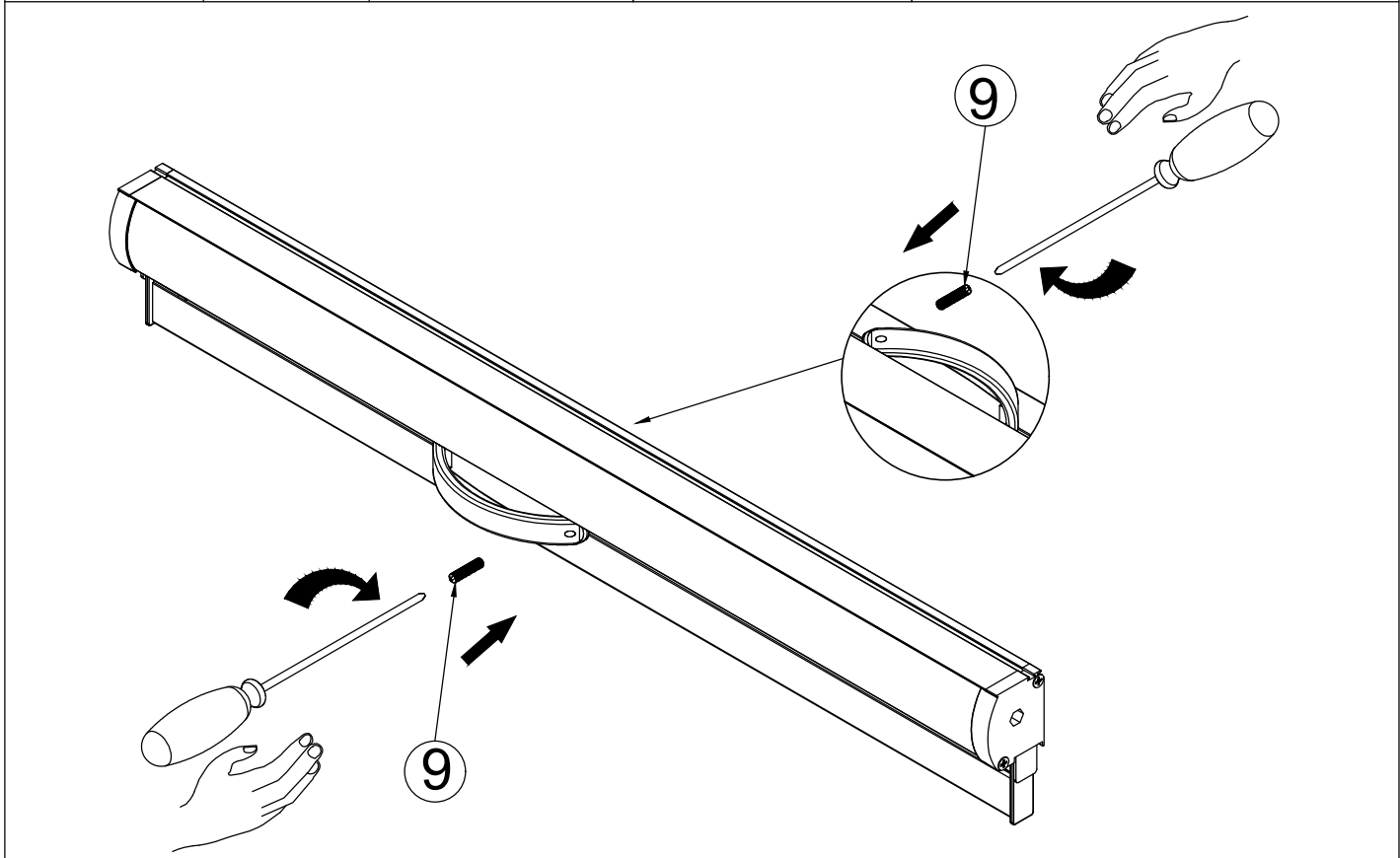

7

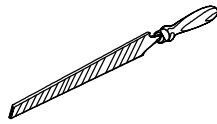
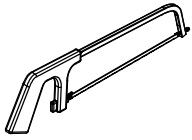

② x2



$W - 55\text{mm} =$

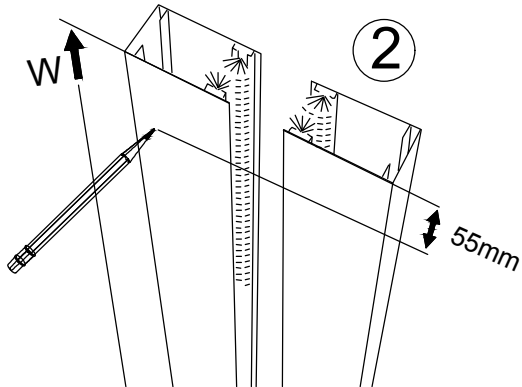
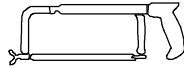

Zum Kürzen der Führungsschienen, nehmen Sie die gemessene Breite (W) minus 55mm.

Pour raccourcir les rails de guidage prendre la largeur mesurée (W) moins 55 mm

Per accorciare i binari, misurare la larghezza (W) e sottrarre 55 mm

Para acortar los rieles toma la medida del ancho (W) y resta 55 mm.

Per a retallar els rails preneu la mida de l'amplada (W) i resteu-hi 55 mm.

Para reduzir o tamanho das calhas tire 55 mm à largura medida (w)

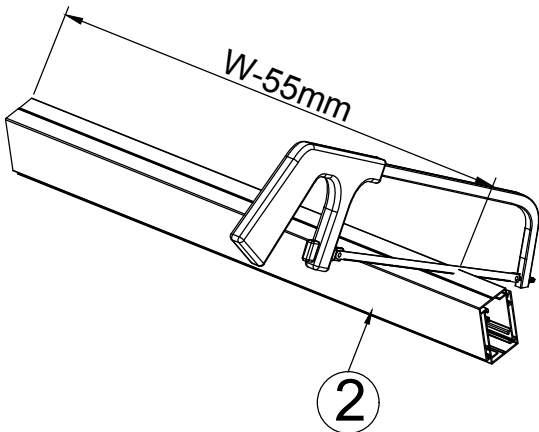

Kürzen Sie die beiden Führungsschienen mit einer Säge. Feilen Sie die Sägekante glatt.

Raccourcir les deux rails de guidage avec une scie. Limez les bords pour les rendre lisses.

Accorciare entrambi i binari servendosi di un seghetto. Limare accuratamente il taglio.

Recorta ambos rieles con una sierra. Lije el corte.

Retalleu les dues rails amb una serra. Escateu el tall.

Reduza as duas calhas com uma serra.

Faça o corte suavemente.

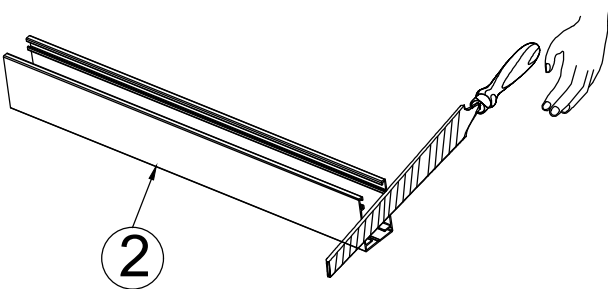

8

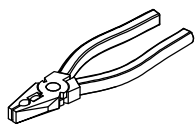

② x2

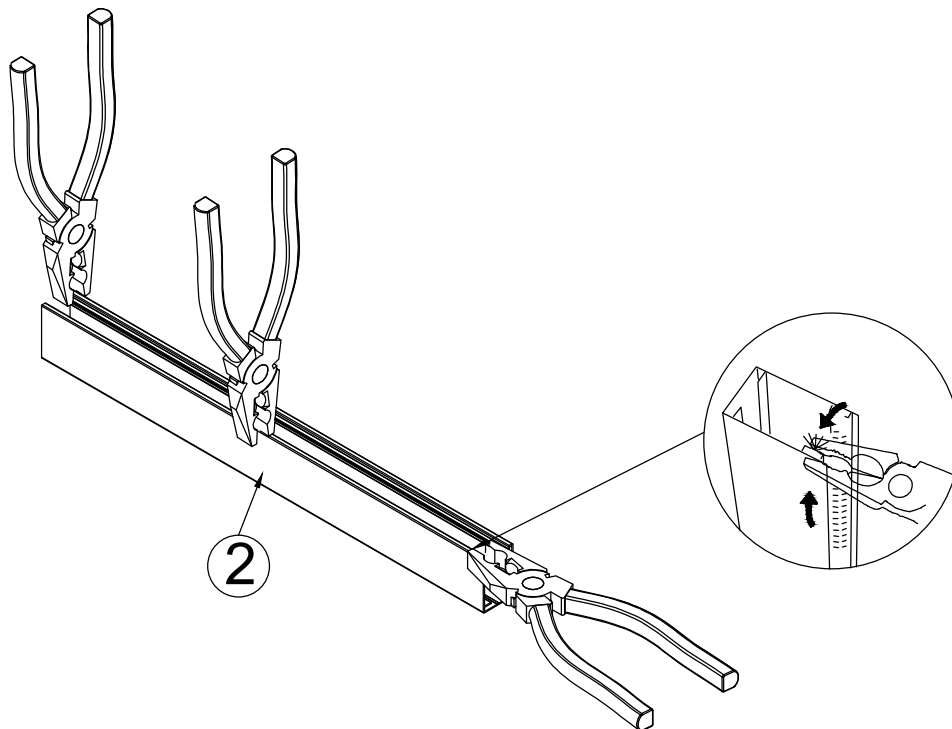

Der Dichtungsstreifen ist vormontiert. Fixieren Sie den Dichtungsstreifen nach dem Kürzen, um zu verhindern, dass dieser in die Führungsschiene rutscht.

Le joint est prémonté. Fixer le joint après avoir raccourci les rails de guidage afin d'empêcher qu'il ne glisse dans le rail.

La striscia isolante è pre-installata. Dopo aver accorciato, fissare la striscia isolante per evitare che questa si muova all'interno del binario.

El burlete está premontado. Después de recortar, fija el burlete; esto impedirá que se mueva dentro del riel.

El rivet està premuntat. Després de retallar, fixe el rivet; això impedeix que se mogui dins de la guia.

A tira para a janela é previamente montada. Depois de reduzir, fixe a fita de vedação para evitar que a mesma se mova para o interior da calha.

9

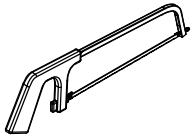

③ x1

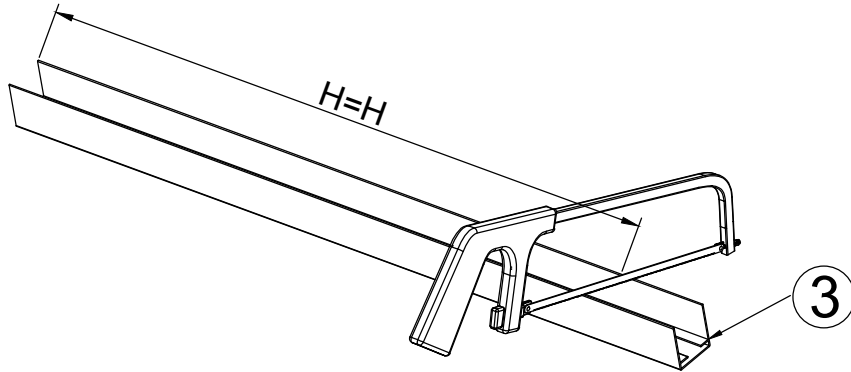
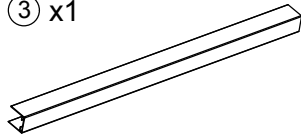

Kürze sie das Ende mit einer Säge

Raccourcir l'extrémité avec une scie

Tagliare l'estremità con un seghetto

Corte el extremo con una sierra

Talleu l'extrem amb una serra.

Reduza o tamanho da extremidade com uma serra

# 10

⑫ x2  
M4x16

⑤ x1

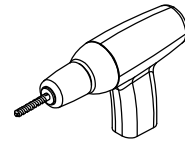
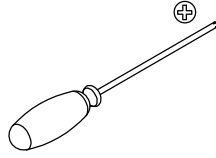
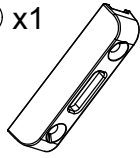

① x1

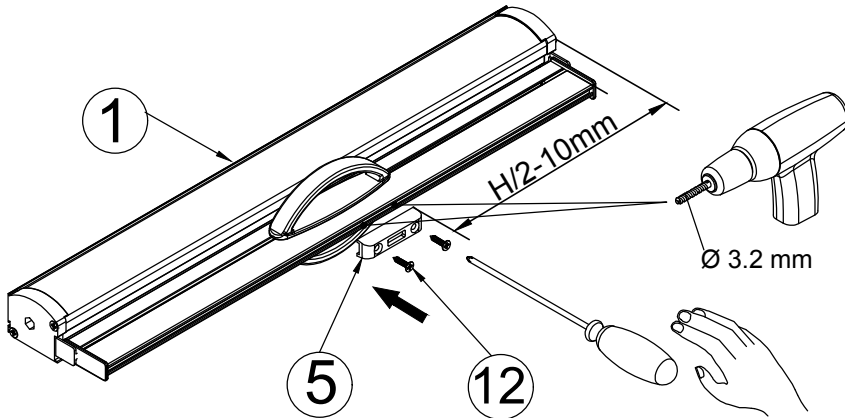
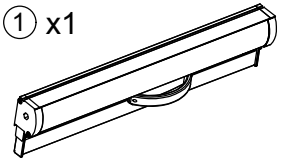

# 11

⑦ x1

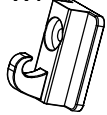

③ x1

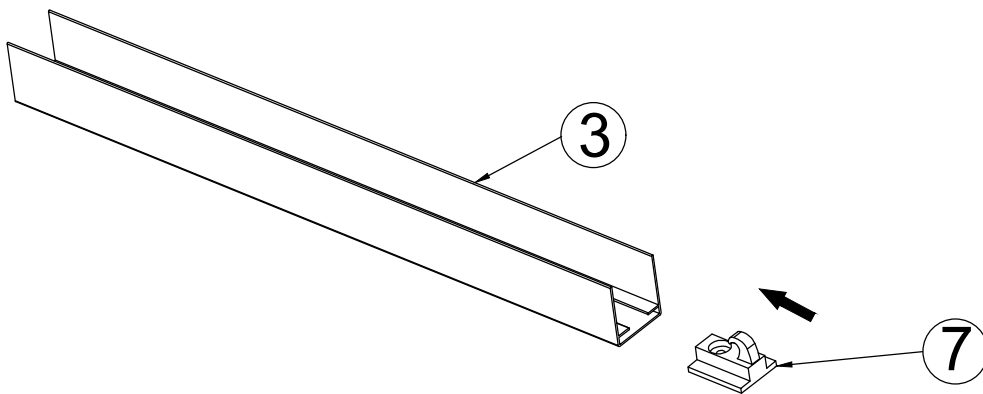
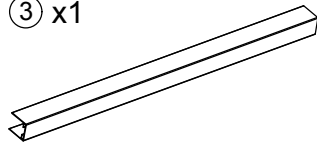

# 12

⑬ x1  
M3x9



① x1

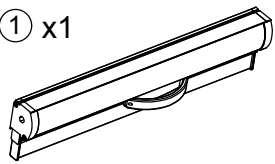

⑦ x1

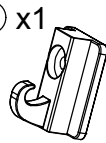

③ x1

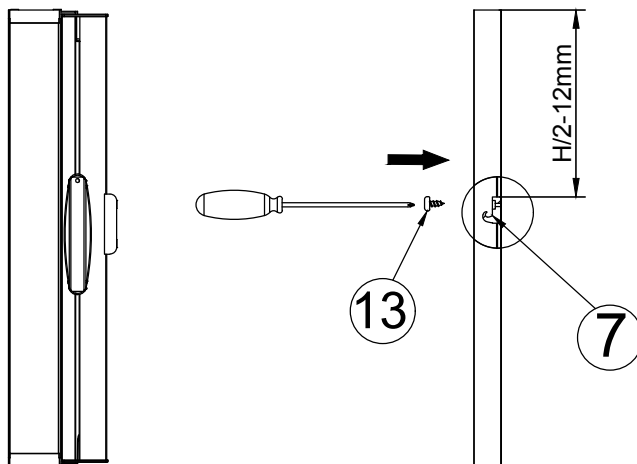
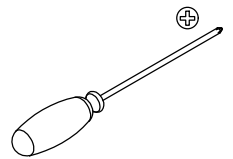
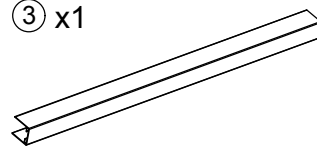

# 13

⑩ x3

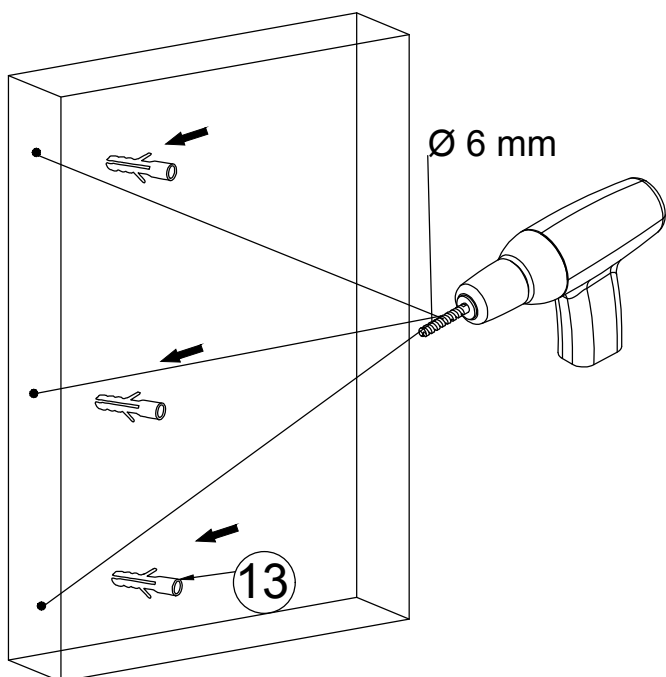
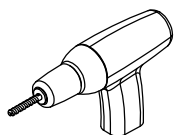

DE : Die mitgelieferten Beschläge eignen sich am besten für gewöhnliche Massivwände – für Rigipswände empfehlen wir Spezialbeschläge, die jedoch nicht mitgeliefert werden!

FR : Les ferrures fournies conviennent pour des murs massifs classiques – pour les murs en placo nous conseillons d'employer des ferrures spéciales, non fournies.

IT : La ferramenta inclusa nella fornitura è adatta per le comuni pareti in muratura. Per pareti in cartongesso raccomandiamo di utilizzare ferramenta specifica, non inclusa nella fornitura.

ES: Los herrajes suministrados son los más adecuados para paredes sólidas comunes; para las paredes de cartón yeso, recomendamos herrajes especiales no incluidos en el producto.

CA: Les ferramentes subministrades són les més adequades per a parets sòlides comuns; per a les parets de cartó guix, recomanem ferramentes especials no incloses en el producte.

PT: As ferragens juntamente fornecidas adequam-se melhor a paredes maciças convencionais – para as paredes de placa de gesso recomendamos a utilização de ferragens especiais que, no entanto, não são fornecidas.

# 14

⑪ x3



M4x25

⑧ x3

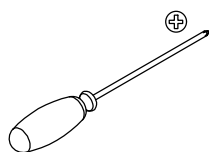

① x1

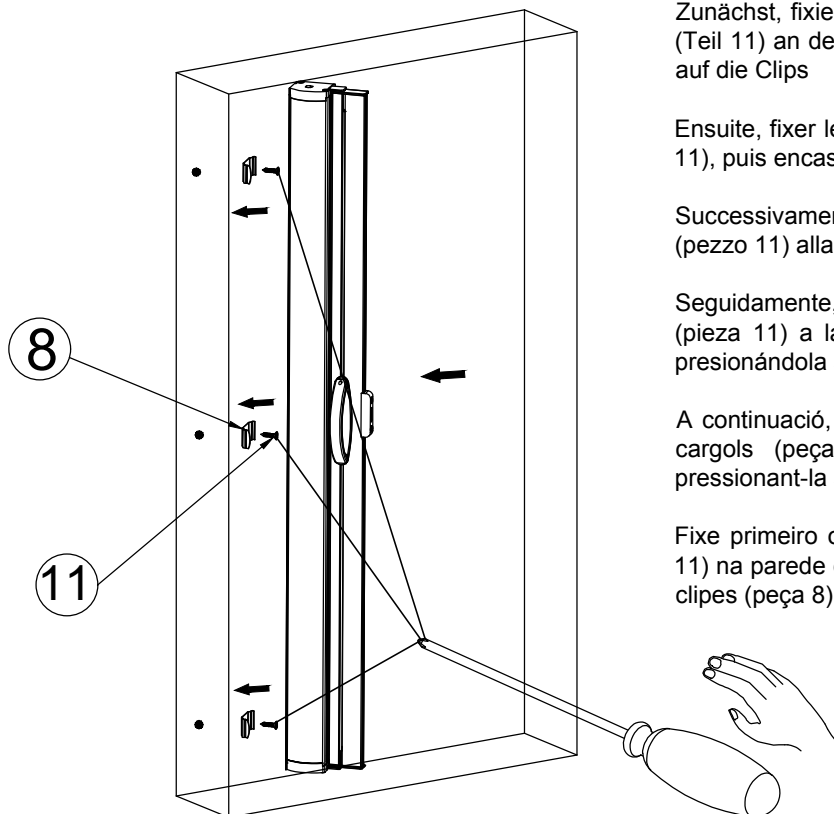

Zunächst, fixieren Sie die 3 Clips (teil 8) mit den Schrauben (Teil 11) an der Wand, dann klicken Sie die Kassette (Teil1) auf die Clips

Ensuite, fixer les 3 clips (pièce 8) au mur avec les vis (pièce 11), puis encastrer le support (pièce 1) sur les clips

Successivamente, fissare le 3 clip (pezzo 8) con le viti (pezzo 11) alla parete, e collocare la cassetta (pezzo 1)

Seguidamente, fije los 3 clips (pieza 8) con los tornillos (pieza 11) a la pared, luego coloque la carcasa (pieza 1) presionándola sobre los clips

A continuació, fixe els 3 clips (peça 8) a la paret amb els cargols (peça 11) i col·loqueu la carcassa (peça 1) pressionant-la sobre els clips (peça 8).

Fixe primeiro os 3 cliques (peça 8) com os parafusos (peça 11) na parede e, de seguida, encaixe o suporte (peça 1) nos cliques (peça 8)

# 15

① x1

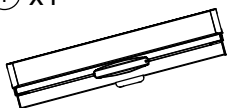

② x2



③ x1

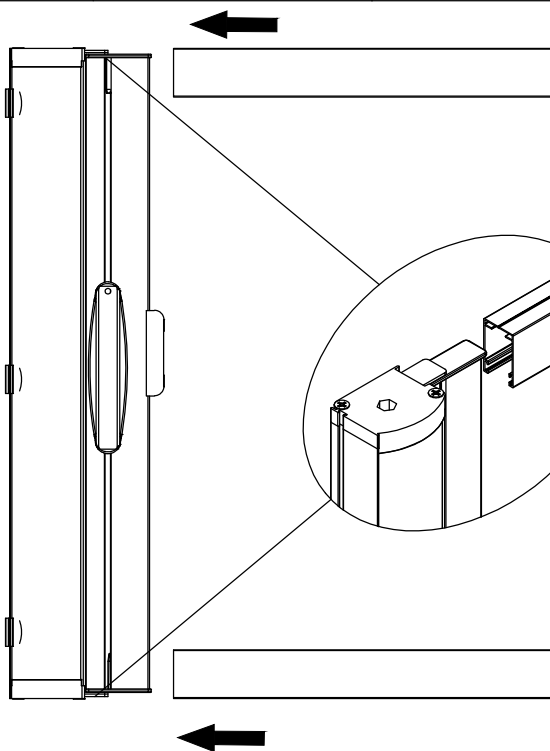
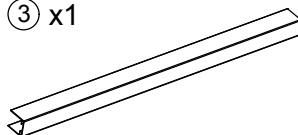

Verbinden Sie die Führungsschienen mit der Kasette.  
Fixieren Sie diese Anschliessend in der Türleibung

Assembler les rails de guidage avec la cassette.  
Puis fixez le au cadre de la porte.

Assemblare i binari con la cassetta.  
Successivamente, fissarlo allo stipite della porta.

Monta los rieles en el cajón.  
A continuación, fíjelo al marco de la puerta.

Munteu el calaix i els rails.  
A continuació, fixe-lo en el marc de la porta.

Monte a cassette e as calhas.  
Depois fixe-as no intradorso da porta.

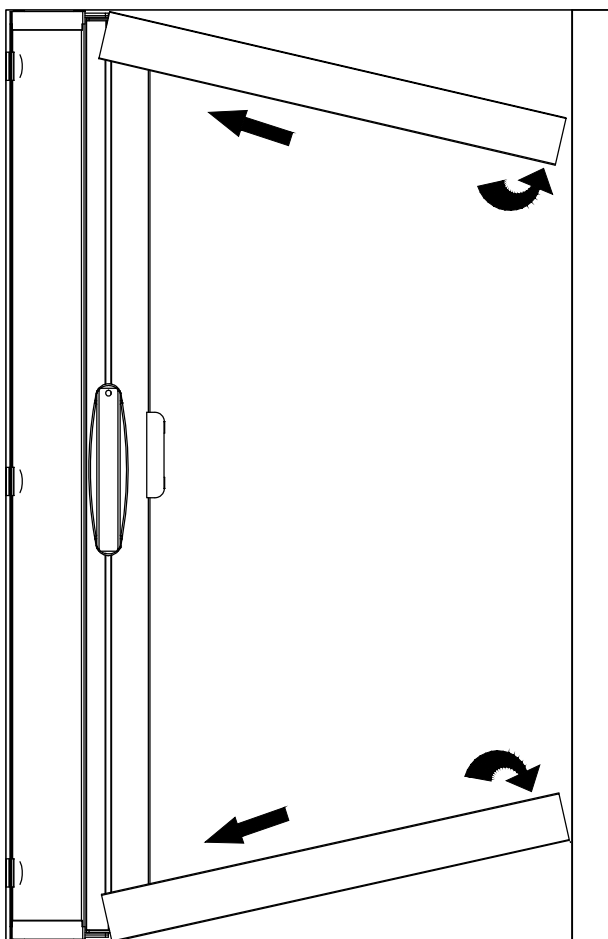

16

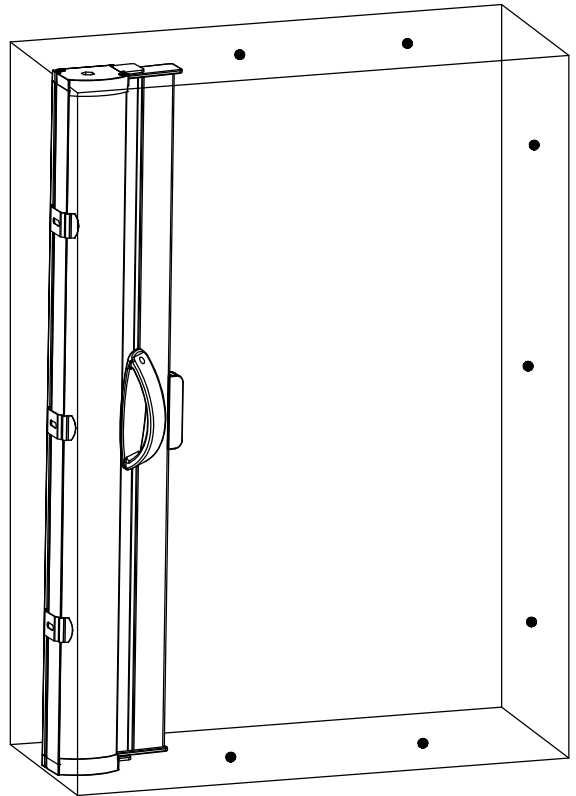
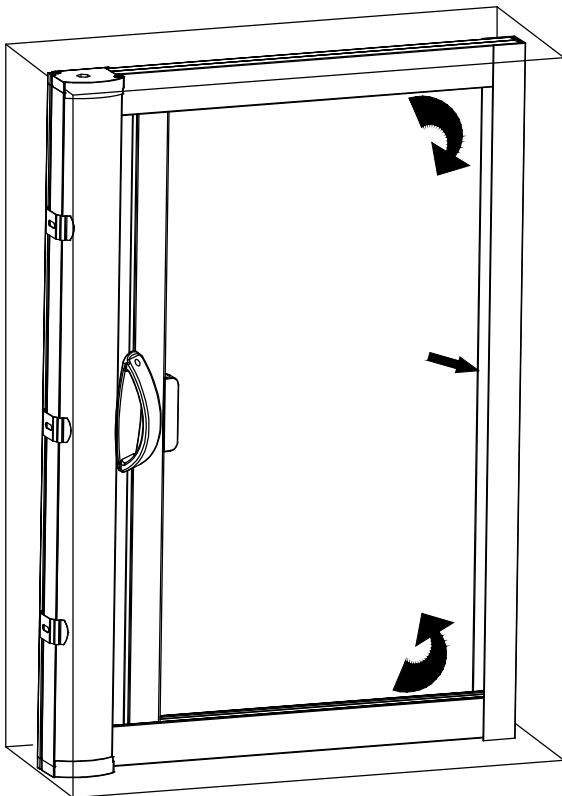
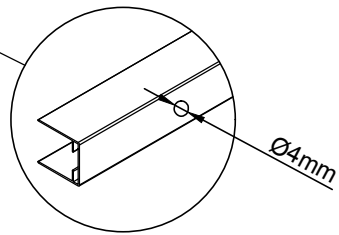
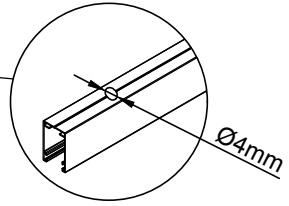
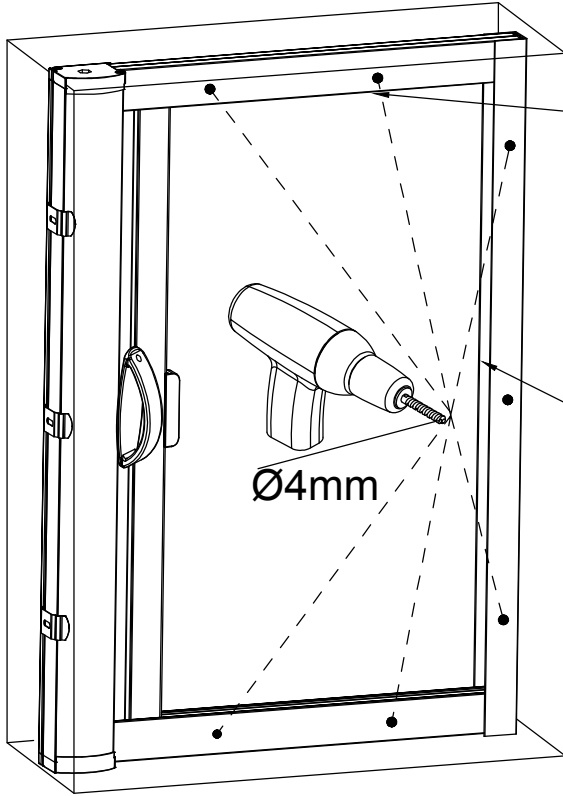
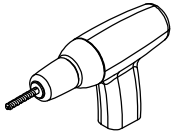

17

⑩ x7

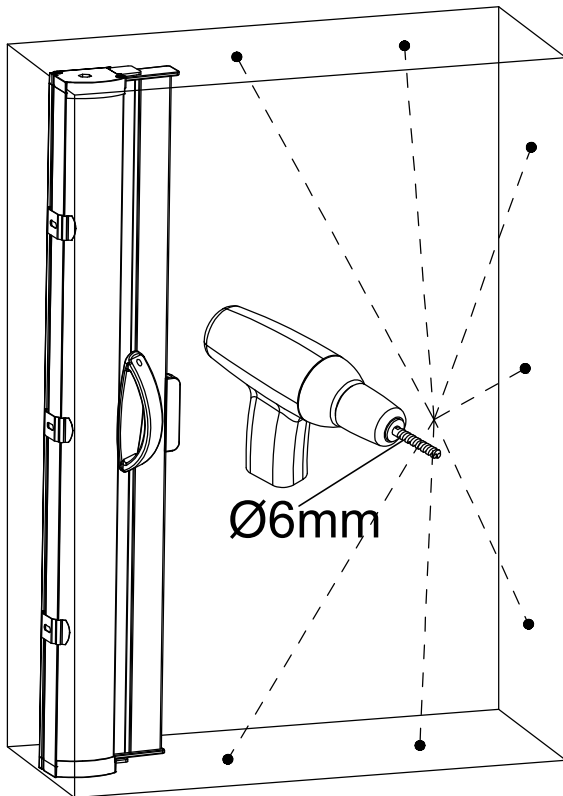
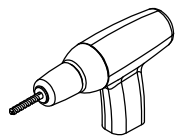

⑩

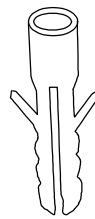

18

⑪ x7

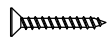

M4x25

